

(2,16mm) .085"

DPAM, DPAF SERIES

HIGH DENSITY DIFFERENTIAL PAIR ARRAY

DPAM Mates with:
DPAF

DPAF Mates with:
DPAM

SPECIFICATIONS

For complete specifications and recommended PCB layouts see www.samtec.com?DPAM or www.samtec.com?DPAF

Insulator Material:

Black LCP

Contact Material:

Copper Alloy

Plating:

Au over 50µ" (1,27µm) Ni

Current Rating (2x3):

2.9A @ 30°C Temperature Rise

Operating Temp Range:

-55°C to +125°C

Contact Resistance:

10.4mΩ max

Working Voltage:

300 VAC

Mated Cycles:

100 Cycles

RoHS Compliant:

Yes

Lead-Free Solderable:

Yes



DPAM	PAIRS PER ROW	07.0	PLATING OPTION	NO. OF ROWS	SOLDER TYPE	A	OPTION
	-04, -06 -08, -15, -23		-S =30µ" (0,76µm) Gold on contact area, Tin on solder tail	-8 =Eight Pair Rows -3 =Three Pair Rows	-2 = Lead-Free Tin Alloy 96.5% Sn/ 3% Ag/.5% Cu Solder Crimp		-K =(20,00mm) 0.80" DIA Polyimide film Pick & Place Pad -TR =Tape & Reel -GP =Guide Post (-23 only)

NO OF ROWS	A
-8	(24,59) .968
-3	(11,89) .468

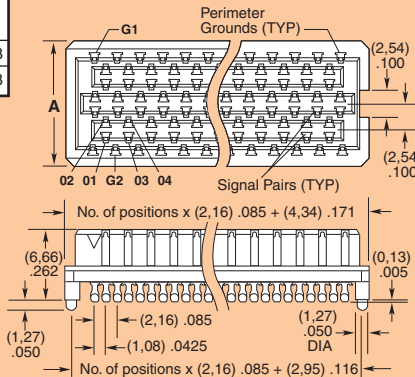

DPAM/DPAF 10mm Stack Height	Rated @ 3dB Insertion Loss*
Single-Ended Signaling	8 GHz / 16 Gbps
Differential Pair Signaling	7 GHz / 14 Gbps

*Performance data includes effects of a non-optimized PCB.
Complete test data available at www.samtec.com?DPAM, www.samtec.com?DPAF or contact sig@samtec.com

Protocols Supported

- Fibre Channel
- Rapid I/O
- PCI Express®
- SATA
- InfiniBand™
- XAUI
- MGT (Rocket I/O)

Download app notes at www.samtec.com/appnote
Contact SIG @ samtec.com for questions on protocols

DPAF	PAIRS PER ROW	03.0	PLATING OPTION	NO. OF ROWS	SOLDER TYPE	A	OPTION
	-04, -06, -08, -15, -23		-S =30µ" (0,76µm) Gold on contact area, Tin on solder tail	-8 =Eight Pair Rows -3 =Three Pair Rows	-2 = Lead-Free Tin Alloy 96.5% Sn/ 3%Ag/ .5% Cu Solder Crimp		-K =(20,00mm) 0.80" DIA Polyimide film Pick & Place Pad -TR =Tape & Reel

NO OF ROWS	A	SIZE	USABLE PAIRS PER ARRAY*
-8	(23,32) .918	-04 x -3	6 Pairs
-8	(23,32) .918	-06 x -3	12 Pairs
-3	(10,62) .418	-04 x -8	16 Pairs
-3	(10,62) .418	-06 x -8	32 Pairs
-3	(10,62) .418	-08 x -8	48 Pairs
-3	(10,62) .418	-15 x -8	104 Pairs
-3	(10,62) .418	-23 x -8	168 Pairs
-3	(10,62) .418	-08 x -3	18 Pairs
-3	(10,62) .418	-15 x -3	39 Pairs
-3	(10,62) .418	-23 x -3	63 Pairs

DPAM LEAD STYLE	DPAF MATED HEIGHT*
-07.0	10mm

*Processing conditions will affect mated height.
*Assumes first and last pair in each row are grounded

ALSO AVAILABLE

Tin-Lead Solder Charge.
Call Samtec.

Note: Other Gold plating options available. Contact Samtec.

Note: Some sizes, styles and options are non-standard, non-returnable.

Due to technical progress, all designs, specifications and components are subject to change without notice.

WWW.SAMTEC.COM