

MICRO MATE CONNECTOR ISDF SERIES
Receptacles & Housings

Rev. Date: 02/27/2009

1. INTRODUCTION

This specification covers the requirements for the application of the Micro Mate ISDF series housings and contacts. These specifications are applicable to all crimping tools.

The illustrations in **Figure 1** define housing and contact features and terminology. Use these terms when corresponding with Samtec personnel to help facilitate your inquiry.

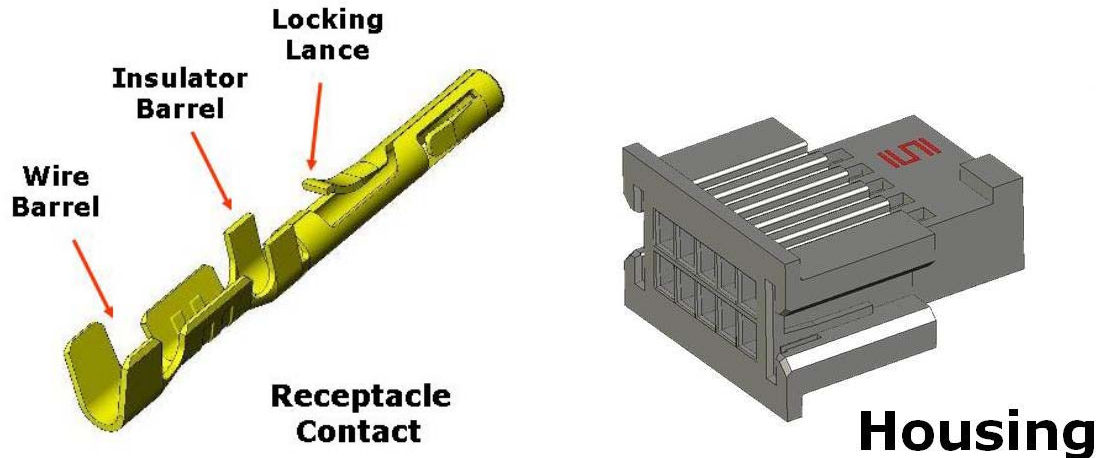

Figure 1

2. CUSTOMER SERVICE Housing

Tooling and product application assistance is available by contacting the **Samtec Application Service Line-(1-800-SAMTEC9)** 8:00 AM to 5:00 eastern time. To expedite your inquiry, have the pertinent part numbers for the product and tooling.

3. DRAWINGS

Customer drawings for specific products are available through Samtec Sales or the Application Service Line. If a conflict in information arises between documents, the customer drawing takes precedence.

4. PRODUCT SPECIFICATIONS

Product Specification <http://www.samtec.com/>– product performance and test information can be found under the Standard Product Link.



MICRO MATE CONNECTOR ISDF SERIES
Receptacles & Housings

Rev. Date: 02/27/2009

5. MANUALS

The following manuals and instruction sheets cover product assembly procedures and tooling operation, setup and maintenance.

Part Number Title

STS-M-001	Quick-change Miniature Applicator (Side-Feed)
STS-M-203-2830-11-A	Application and Maintenance for Hand Crimping tool- CAT-HT-203-2830-11
STS-M-003	Terminating Press- CAT-3000
STS-N-003	Extraction & Lance Reset Tool

6. PRODUCT STORAGE

6.1 Connector Reels

Reeled contacts should be stored horizontally and in the shipping container to prevent damage.

6.2 Ultraviolet Exposure

Prolonged exposure to ultraviolet light may degrade the material used in the housings.

6.3 Shelf Life

The housings and contacts should be used on a first in, first out basis to avoid the possibility of contamination that could affect electrical performance.

MICRO MATE CONNECTOR ISDF SERIES
Receptacles & Housings

Rev. Date: 02/27/2009

7. WIRE SELECTION AND PREPARATION

The wire size range and stripped dimensions in mm (inches) are shown in **Table 1**. Care must be taken to avoid cut strands, nicks and scrapes during the stripping operation.

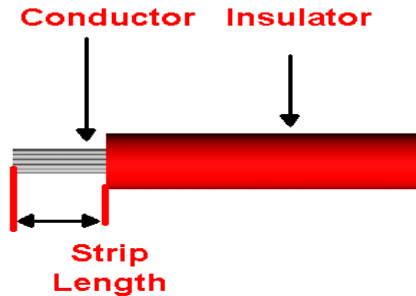

This picture is for illustration purposes only.

WIRE SIZE (AWG)	INSUL DIA RANGE	STRIP LENGTH	WIRE BARREL		INSUL BARREL CRIMP WIDTH	CRIMP TENSILE
			CRIMP HEIGHT	CRIMP WIDTH		
28	.74-.97 (.029-.038)	2.28-2.54 (.092-.098)	0.46 ± 0.025 (.0180 ± 0.001)	0.81 ± 0.05 (.0320 ± 0.002)	.97 ± 0.05 (.0380 ± 0.002)	3.2#
30			0.41 ± 0.025 (.0160 ± 0.001)			2.1#

Table 1: mm (inches)

Refer to the appropriate tooling manual for directions on contact placement, wire placement and tool settings. Refer to **Figure 3** for acceptable crimp conditions.

7.1 Wire Crimp Height

The crimping operation on the wire barrel portion of the contact is critical to ensuring optimum electrical and mechanical performance. The wire barrel seam must be closed with all wire strands in the crimp. The crimp heights must be within the limits specified in **Table 1**.

7.2 Insulation Crimp Height

The insulation barrel should firmly grip the wire's insulation. The final crimp height is determined by outside diameter of the wire.

7.3 Front and Rear Bellmouth

The rear bellmouth is critical to ensuring maximum tensile strength of the crimp. Both front and rear bellmouths shall be present and conform to the dimensions in **Figure 2**.



MICRO MATE CONNECTOR ISDF SERIES
Receptacles & Housings

Rev. Date: 02/27/2009

7.4 Cutoff Tab and Burr

The cutoff tab and burr shall conform to the dimensions shown in **Figure 2**. Excessive burr is an indication of worn tooling that must be corrected.

7.5 Wire Crimp Flash

The wire barrel flash shall not exceed .02 (.008) as shown in **Figure 3**. Excessive flash is an indication of worn tooling or incorrect crimp height and should be corrected immediately.

7.6 Crimp Location

The crimp area must be in the location shown in **Figure 2** for maximum effectiveness. The wire barrel seam shall be closed and properly formed with no wire strands protruding from the seam.

7.7 Wire Location

The wire is properly located in a finished crimp when equal amounts of insulation and wire are visible between the barrels. Wire must also be visible at the receptacle end of the wire barrel and satisfy the dimension shown in **Figure 2**.

7.8 Twist

The extrusion created from the force of the crimping process can cause some deformation in the overall shape of the contact. After crimping, there shall be no twist or other damage to the mating portion of the contact that will prevent proper mating as shown in **Figure 4**.

7.9 Straightness

The crimping process can also cause some bending along the length of the contact, which can prevent proper insertion of the contact into its housing cavity. Such deformation is acceptable within the following limits as shown in **Figure 4**.

MICRO MATE CONNECTOR ISDF SERIES
Receptacles & Housings

Rev. Date: 02/27/2009

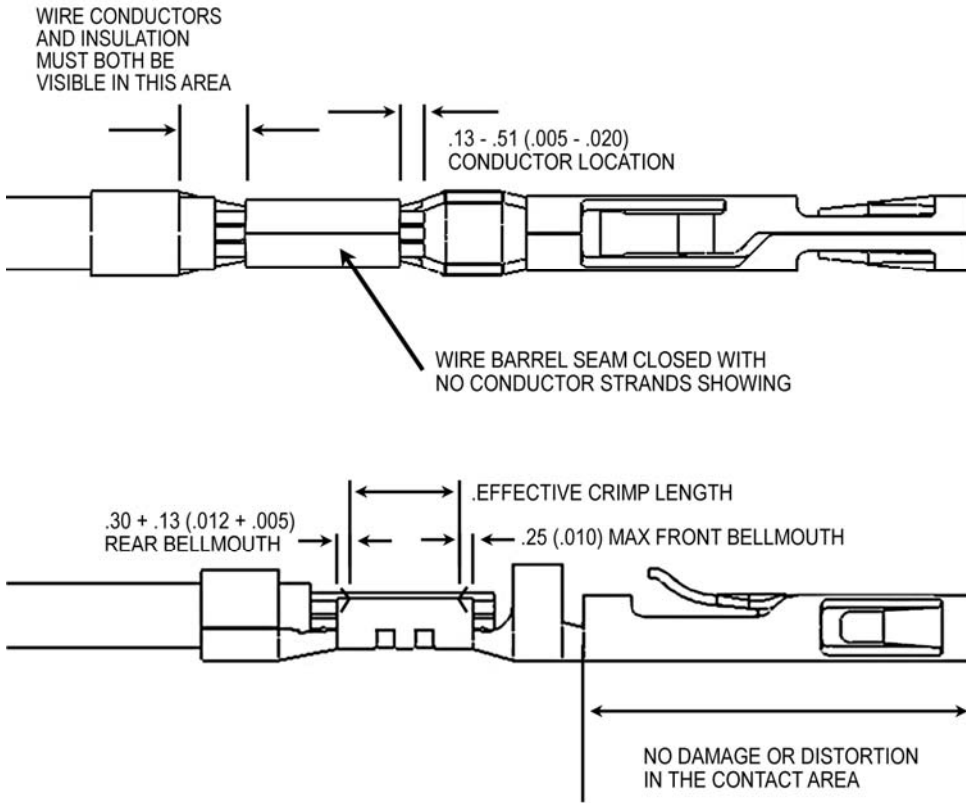

Figure 2

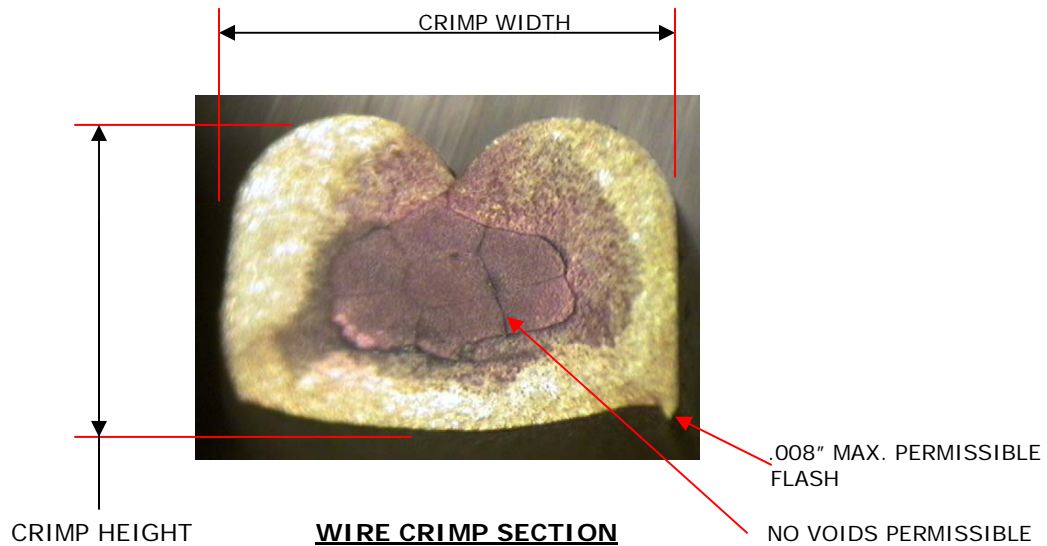

Figure 3

MICRO MATE CONNECTOR ISDF SERIES
Receptacles & Housings

Rev. Date: 02/27/2009

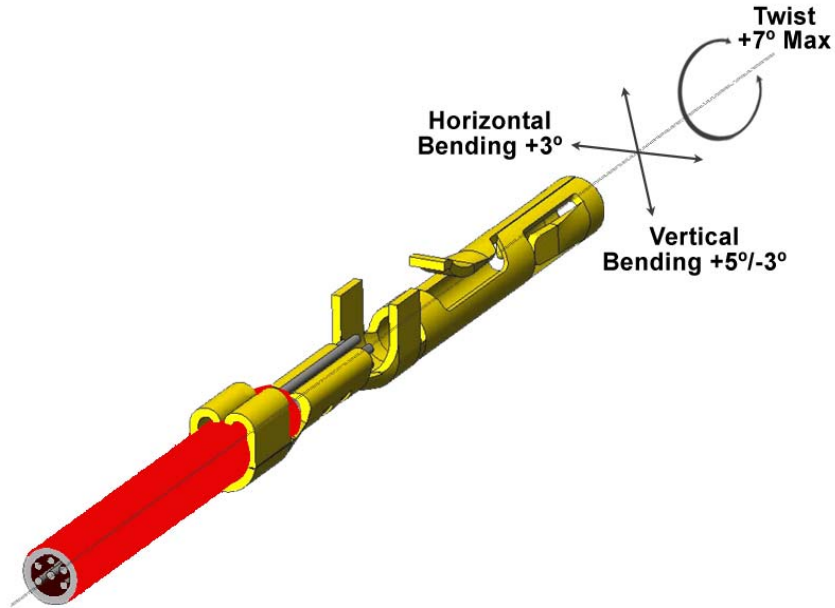

Figure 4

8. Housings

The housings are available in a variety of configurations. The sizes range from 5 through 30 positions and have position identification numbers molded on the back surface. See **Figure 5**.

Housings can come in a number of configurations (including polarized and keyed features)

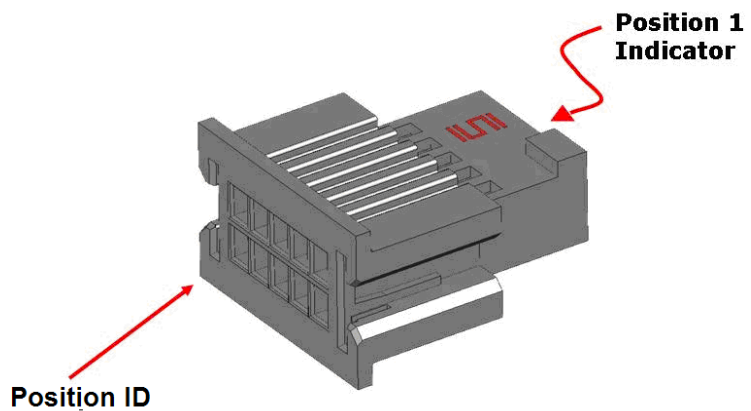

Figure 5

MICRO MATE CONNECTOR ISDF SERIES
Receptacles & Housings

Rev. Date: 02/27/2009

9. Contact and Housing Assembly

To insert a contact into housing, align the contact with the desired cavity at the rear of the housing as shown in Figure 6. In all rows the locking lance must be facing opposite the central rib to engage the contact in the cavity. Push the contact straight into the cavity until an audible **click** is heard. Give the lead a light tug to confirm that the contact is locked in place.

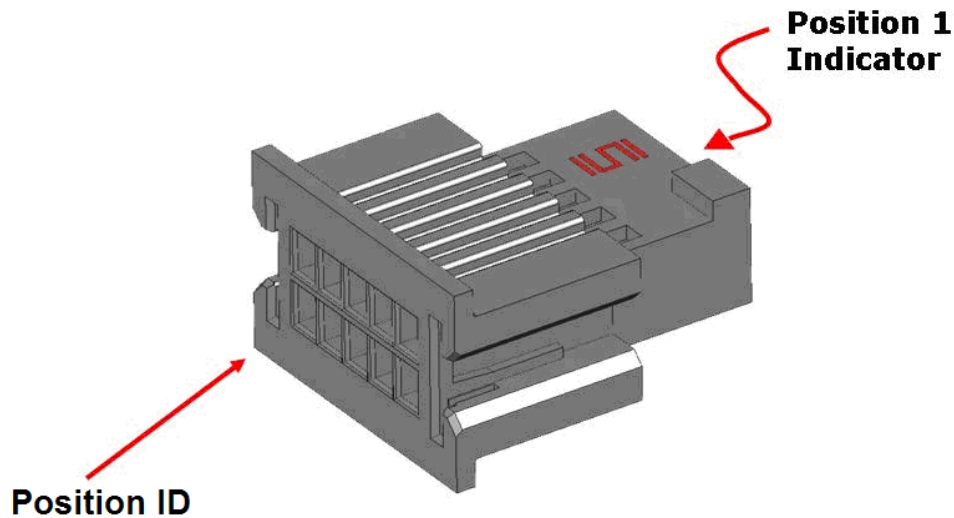

Figure 6

10. Tooling

Table 2 shows the tool part numbers and operation manuals related to wire size. The links below offer pictures and contact information.

Hand Tooling –

http://www.samtec.com/rugged_power/application_tooling/hand_tools.aspx?nav=1535,

Mini Applicators -

http://www.samtec.com/rugged_power/application_tooling/mini_applicators.aspx?s=ai&nav=1290.

Hand crimping tools accommodate the complete wire range and are designed for low-volume production and repair.

Quick Change Applicators are designed to accept strip-fed contacts and have up to four wire and insulation crimp height settings. This tooling can be provided for 30mm or 40mm stroke presses with a post or pre-contact feeding. In bench machines, the contact should be in the crimp area when the press is at rest so the pre-feed feature is appropriate. In automatic lead making equipment, the contact is fed on the down stroke of the press so the post-feed feature should be selected



MICRO MATE CONNECTOR ISDF SERIES
Receptacles & Housings

Rev. Date: 02/27/2009

Extraction Tooling - Locking Lance resetting is not recommended, but a contact can be reused if its extraction is done with great care and without damage to the lance.

Use extraction tool CAT-EX-169-01 for removing contacts from the housing and CAT-RE-169-01 for resetting the lance if required. Instruction sheet STS-N-003 describes the tools and the extraction process.

Table 2 shows the tool part numbers and operation manuals related to wire size.

AWG Range	Insul dia. Range	Applicator Part No. (Manual No.)	Hand Tool Part No. (Manual No.)	Bench Press No. (Manual No.)
28-30	.74-.97 (.029-.038)	CAT-MA-203-2830-11-TR 30mm stroke pre feed (STS-M-001)	CAT-HT-203-2830-11 (STS-M-203-2830-11-A)	CAT-3000-01 Basic Press 40mm Stroke (STS-M-003)
		CAT-MA-203-2830-11-FR 40mm stroke pre feed (STS-M-001)		CAT-3000-02 Press with Precision Adj. 40mm Stroke (STS-M-003)
		CAT-MA-203-2830-11-FS 40mm stroke post-feed (STS-M-001)		CAT-3000-03 Press with CQM & Precision Adj. 40mm Stroke (STS-M-003)
				CAT-3000-04 Press with Strip Module & Precision Adj. 40mm Stroke (STS-M-003)
				CAT-3000-05 Press with Strip Module, Precision Adj. & CQM sensor 40mm Stroke (STS-M-003)

Table 2