

DO NOT SCALE FROM THIS PRINT

DESIGNED & DIMENSIONED IN MILLIMETERS [INCHES]

SMB5-P-C-H-ST-CA1

GENDER
-P: PLUG

TYPE
-C: CABLE TERMINATED

PLATING
-H: HEAVY

TERMINATION
-CA1: CABLE (RG174 & RG316)

ORIENTATION
-ST: STRAIGHT

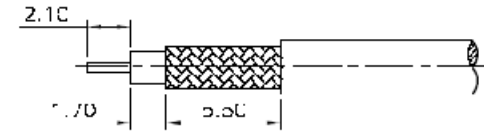
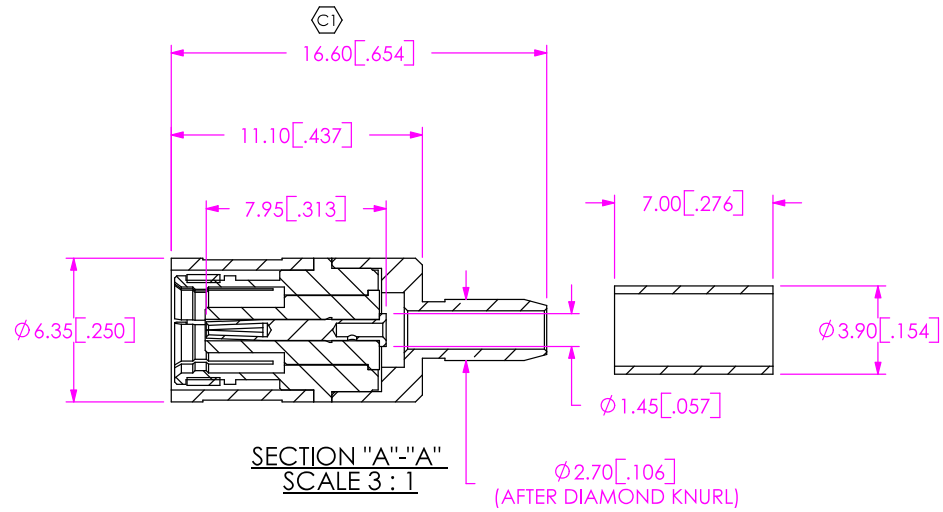
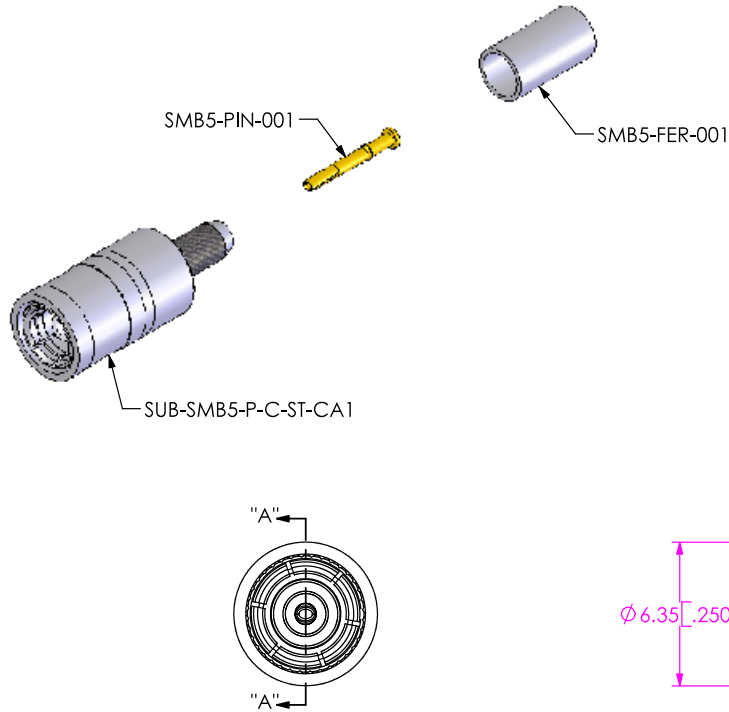

NOTES:

1. (C) REPRESENTS A CRITICAL DIMENSION.
2. COMPONENTS TO BE PACKAGED INDIVIDUALLY AND ASSEMBLY TO BE SOLD AS A KIT.
3. PLATING IS TO BE CHECKED.
4. MAX BURR ALLOWANCE: .051
5. FABRICATED PARTS MUST BE FREE OF SCRATCHES, TOOL MARKS, ETC.

TABLE 1: MATERIAL

SAMTEC PART No	ITEM	MATERIAL	FINISH
SUB-SMB5-P-C-ST-CA1	CABLE BODY	BRASS C3602B	Cu0.75um Ni2.50um
	SHELL	BRASS C3602B	Cu0.75um Ni2.50um
	OUTER SHELL	BRASS C3602B	Cu0.75um Ni2.50um
	INSULATOR	TEFLON	
	C-RING	BeCu C17300	Cu0.75um Ni2.50um
SMB5-PIN-001	PIN	BeCu	Au0.75um
SMB5-FER-001	FERRULE	BRASS C26000	Cu0.75um Ni2.50um

UNLESS OTHERWISE SPECIFIED, DIMENSIONS ARE IN MILLIMETERS. TOLERANCES ARE:
 DECIMALS ANGLES
 .X: ±.3 [.01] 2°
 .XX: ±.10 [.005]
 .XXX: ±.050 [.002]

PROPRIETARY NOTE
 THIS DOCUMENT CONTAINS INFORMATION CONFIDENTIAL AND PROPRIETARY TO SAMTEC, INC. AND SHALL NOT BE REPRODUCED OR TRANSFERRED TO OTHER DOCUMENTS OR DISCLOSED TO OTHERS OR USED FOR ANY PURPOSE OTHER THAN THAT WHICH IT WAS OBTAINED WITHOUT THE EXPRESSED WRITTEN CONSENT OF SAMTEC, INC.

SAMTEC

520 PARK EAST BLVD, NEW ALBANY, IN 47150
 * PHONE: 812.944.6733 FAX: 812.948.5047
 e-Mail: INFO@SAMTEC.COM CODE: 55322

MATERIAL: DO NOT SCALE DRAWING SHEET SCALE: 2:1
 SEE TABLE 1



DESCRIPTION:
 SMB STR PLUG FOR RG174 & RG316 CBLE

DWG. NO. **SMB5-P-C-H-ST-CA1**

BY: TIM P. 3/08/2006 SHEET 1 OF 1