

REVISION

0	DF	D FRALEY
3/24/2008	ECN-88093	ISSUE FOR REVIEW.
A	TT	D Fletcher
5/12/2008	ECN-90718	RELEASE FOR PRODUCTION.

B	JB	D FRALEY
10/9/2008	ECN-98688	SHT 1, BOM: CHG WT-29-01-F TO WT-29-07-F; TOP VIEW: ADD DIM 13.00 REF; FRONT VIEW: DEL DIM 13.00 REF, ADD DIM 12.90

C	MM	E Fox
5/29/2009	ECN-111137	FRONT VIEW: CHG DIM "14.79" TO "14.79 +/- .33".

D	MM	D FRALEY
10/22/2009	ECN-118817	BOM: ITEM 1 CHG FROM ASP-136452-04-B TO ERM8-011-01-D-EM2

DATE: _____
 COMPANY: _____
 CUSTOMER SIGNATURE _____
 PRINTED NAME _____
 PHONE No: _____
 FAX No: _____

ITEM NO.	PART NUMBER	QUANTITY	MATERIAL
1	ASP-136452-04-B	1.0000	VECTRA E130i, COLOR:BLACK
2	T-1M47-01-S	20.000	PHOS BRONZE, 521 HT
3	T-1M47-03-S	20.000	PHOS BRONZE, 521 HT
4	WT-29-07-F	2.0000	BeCu #25, 1/2 HT
5	TY-ASP120	1.0000	BLACK HIPS

- NOTES:
 1. ITEM 1 IS NOT AVAILABLE AS A STANDARD
 2. Ⓢ REPRESENTS A CRITICAL DIMENSION.
 3. MAXIMUM BURR ALLOWANCE: .038[.0015].
 4. MINIMUM PUSHOUT FORCE: 2.22N [.5 LB].
 5. PARTS TO BE PACKAGED IN TRAYS.

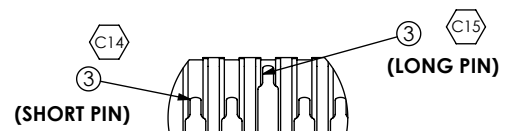
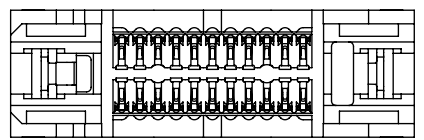
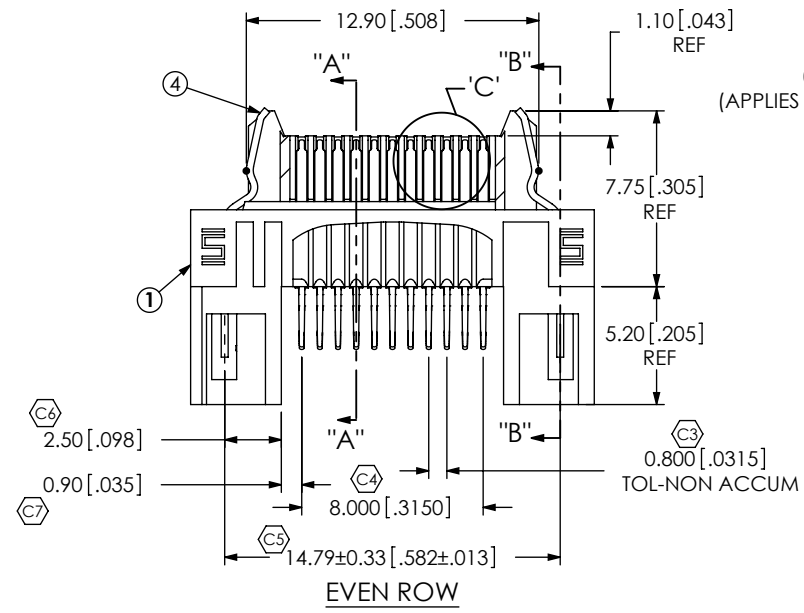
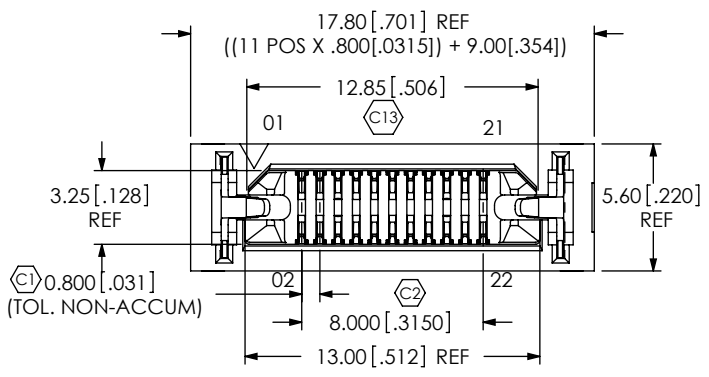

DETAIL 'D'
SCALE 6:1

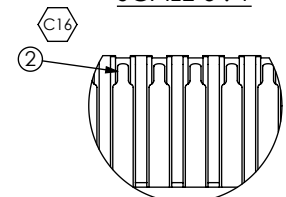

DETAIL 'C'
SCALE 6:1

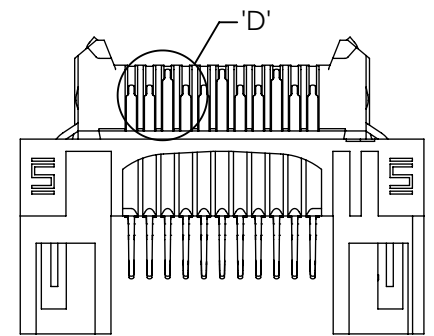

ODD ROW (DP SIDE, HOT PLUG SIDE)

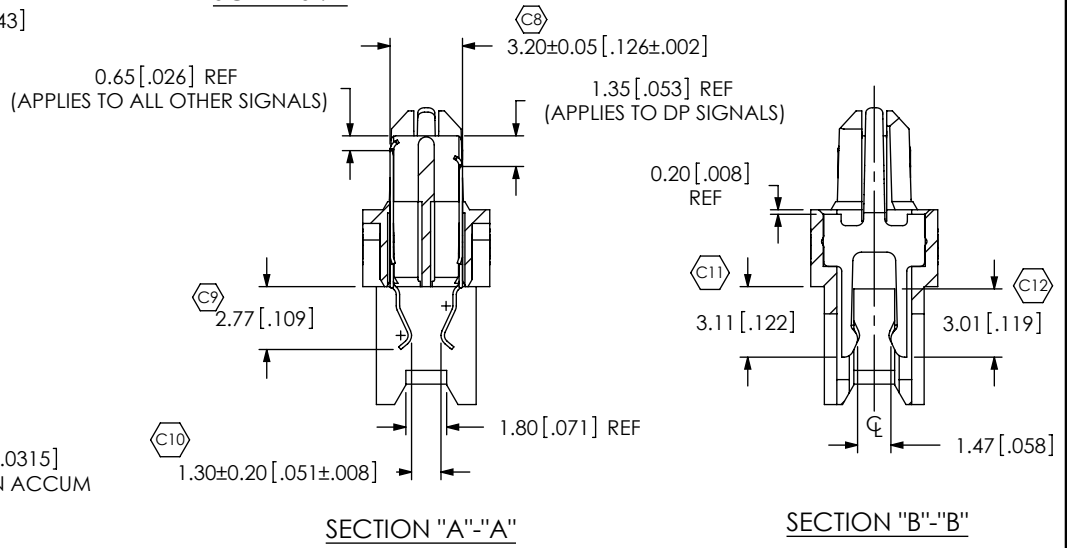

SECTION "A"-A

SECTION "B"-B

UNLESS OTHERWISE SPECIFIED, DIMENSIONS ARE IN MILLIMETERS
 TOLERANCES ARE:
 DECIMALS ANGLES
 .X: ±.3[.01]
 .XX: ±.13[.005]
 .XXX: ±.051[.0020]

PROPRIETARY NOTE
 THIS DOCUMENT CONTAINS INFORMATION CONFIDENTIAL AND PROPRIETARY TO SAMTEC, INC. AND SHALL NOT BE REPRODUCED OR TRANSFERRED TO OTHER DOCUMENTS OR DISCLOSED TO OTHERS OR USED FOR ANY PURPOSE OTHER THAN THAT WHICH IT WAS OBTAINED WITHOUT THE EXPRESSED WRITTEN CONSENT OF SAMTEC, INC.



520 PARK EAST BLVD, NEW ALBANY, IN 47150
 PHONE: 812-944-6733 FAX: 812-948-5047
 e-Mail: info@SAMTEC.com code: 55322

DO NOT SCALE DRAWING SHEET SCALE: 1:0.3333333333333333
 PLATING:
 CONTACT AREA: .000030 GOLD OVER .000050 NICKEL
 REMAINDER: .000200 REF TIN OVER .000050 NICKEL
 LATCHES: .000003 GOLD OVER .000050 NICKEL

DESCRIPTION: MODIFIED ERM8 ASSEMBLY
 DWG. NO. ASP-137971-01
 BY: David F 01/30/2008 SHEET 1 OF 2

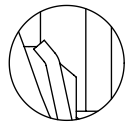

DETAIL 'G'
SCALE 6 : 1

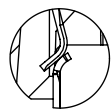

DETAIL 'H'
SCALE 6 : 1

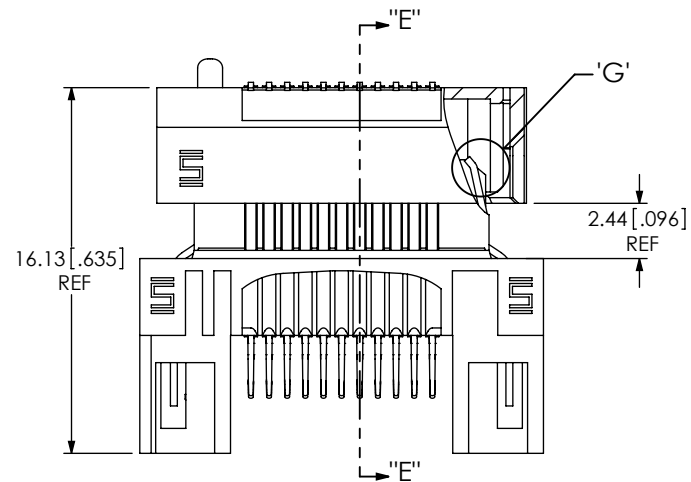

LATCH ENGAGING VIEW

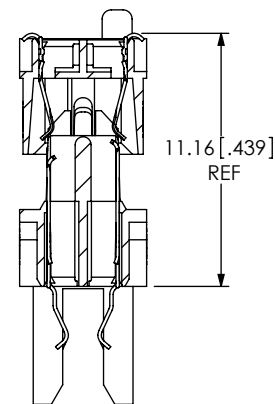

SECTION "E"-"E"

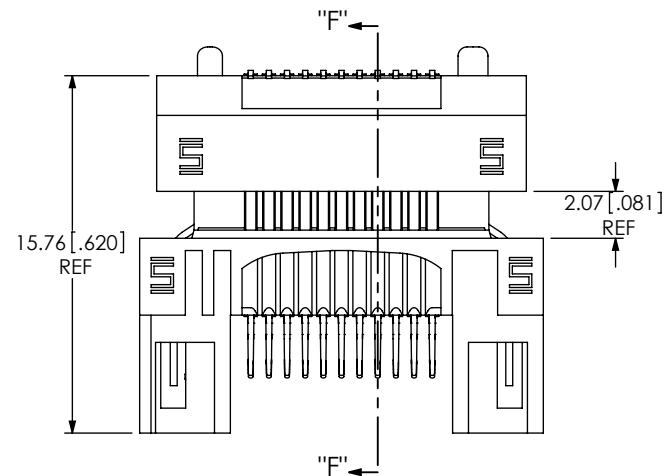

PIN ENGAGING VIEW

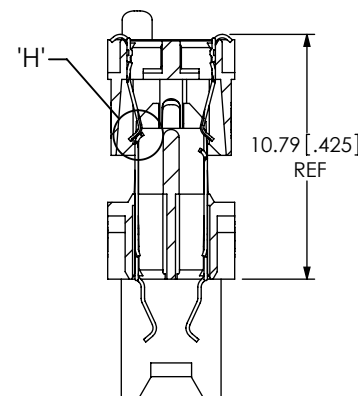

SECTION "F"-"F"

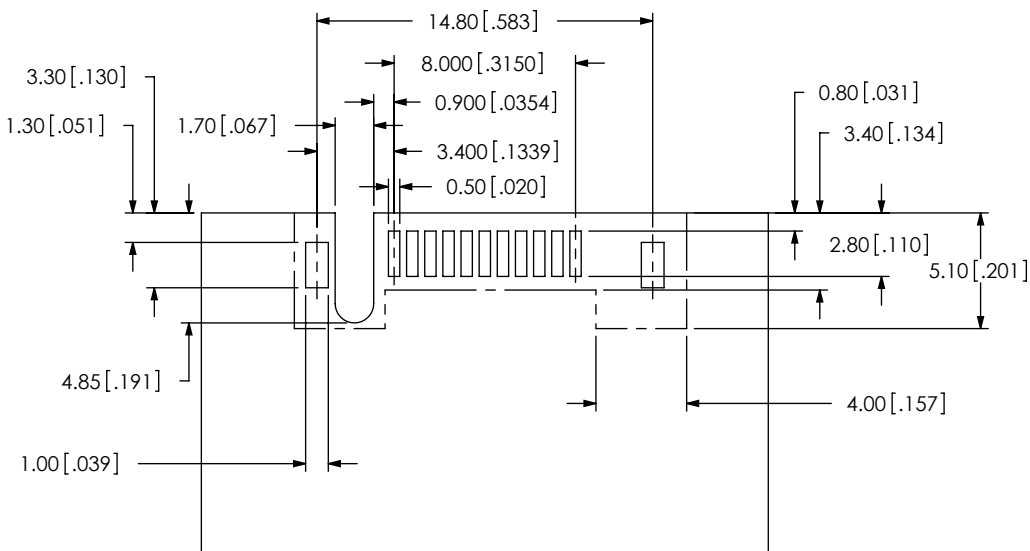

RECOMMENDED PCB LAYOUT

PROPRIETARY NOTE

THIS DOCUMENT CONTAINS INFORMATION CONFIDENTIAL AND PROPRIETARY TO SAMTEC, INC. AND SHALL NOT BE REPRODUCED OR TRANSFERRED TO OTHER DOCUMENTS OR DISCLOSED TO OTHERS OR USED FOR ANY PURPOSE OTHER THAN THAT WHICH IT WAS OBTAINED WITHOUT THE EXPRESSED WRITTEN CONSENT OF SAMTEC, INC.



520 PARK EAST BLVD, NEW ALBANY, IN 47150
PHONE: 812-944-6733 FAX: 812-948-5047
e-Mail: info@SAMTEC.com code: 55322

SHEET SCALE: 3:1

DESCRIPTION: MODIFIED ERM8 ASSEMBLY

DWG. NO. ASP-137971-01