

REVISION

0	DF	D FRALEY
3/24/2008	ECN-88091	ISSUE FOR REVIEW.
A	MM	D Fletcher
5/14/2008	ECN-90925	RELEASE FOR PRODUCTION.
B	MM	D Fletcher
8/1/2008	ECN-95067	BOM: CHG THE QTY OF T-1M47-01-S AND T-1M47-03-S TO 17; DELETED NOT APPROVED BLOCK; TOP VIEW: CHG POSITION NUMBER 34 TO 33 AND 35 TO 34.
C	MM	D FRALEY
9/29/2008	ECN-97953	SHEET 1: FRONT VIEW CHG 19.60 TO 19.60±.33; SHEET 2: FRONT VIEW: CHG 19.60 TO 19.60±.33

NOTES:

1. ITEM 1 IS NOT AVAILABLE AS A STANDARD
2. Ⓢ REPRESENTS A CRITICAL DIMENSION.
3. MAXIMUM BURR ALLOWANCE: .038[.0015].
4. MINIMUM PUSHOUT FORCE: 2.22N [.5 LB].
5. PARTS TO BE PACKAGED IN TRAYS.

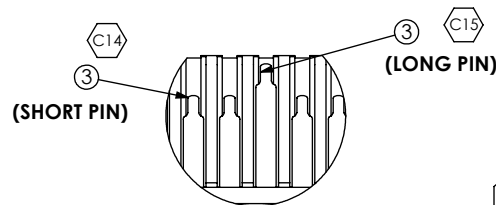
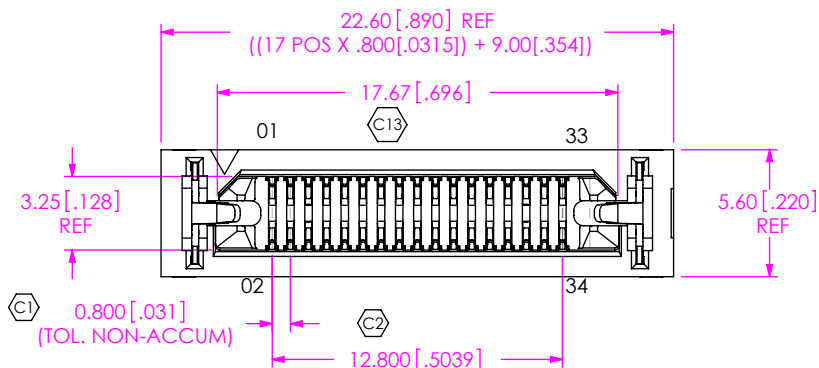

DETAIL 'D'
SCALE 6:1

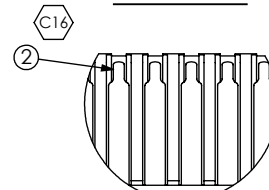

DETAIL 'C'
SCALE 6:1

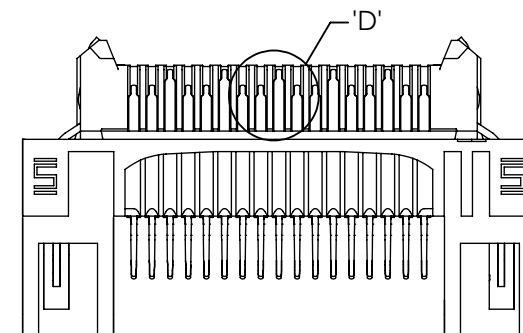

ODD ROW (DP SIDE, HOT PLUG SIDE)

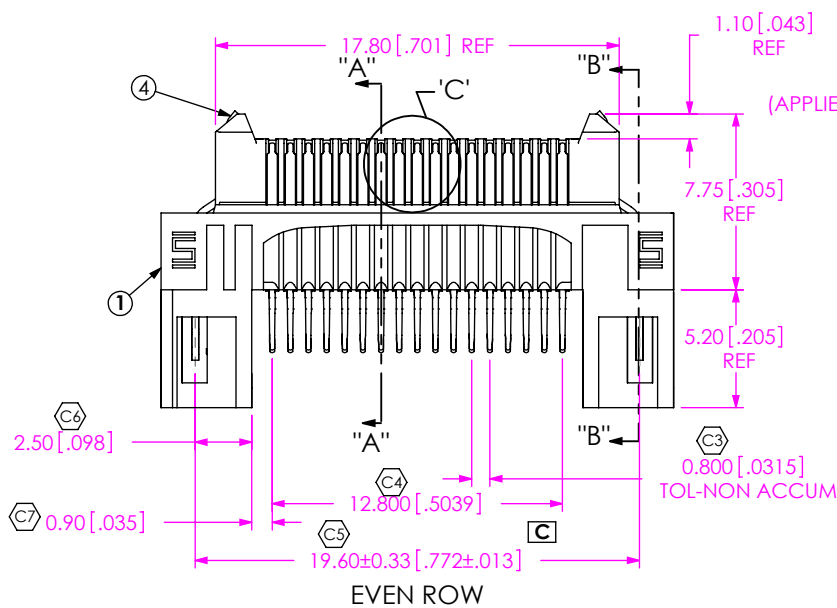

EVEN ROW

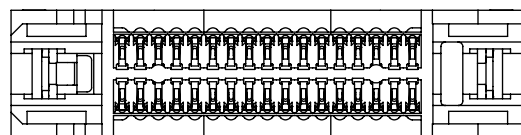

13.57 [REF]

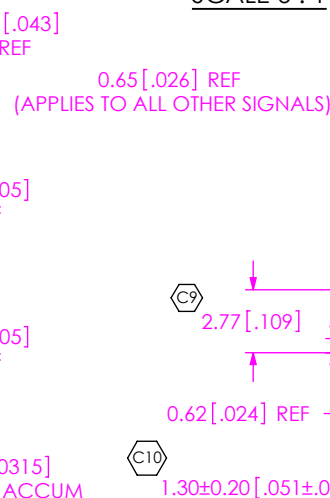

SECTION "A"- "A"

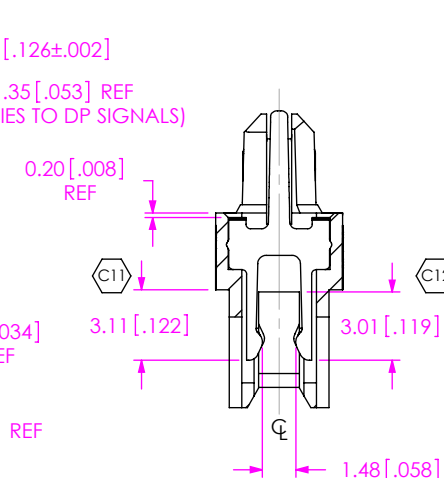

SECTION "B"- "B"

DATE: _____
 COMPANY: _____
 CUSTOMER SIGNATURE _____
 PRINTED NAME _____
 PHONE NO: _____
 FAX No: _____

ACCEPTANCE OF DRAWING
 ACCEPTED WITH DEVIATIONS LISTED

UNLESS OTHERWISE SPECIFIED, DIMENSIONS ARE IN INCHES.
 TOLERANCES ARE:
 DECIMALS ANGLES
 .X: ±.3[.01] 2°
 .XX: ±.13[.005]
 .XXX: ±.051[.0020]

PROPRIETARY NOTE
 THIS DOCUMENT CONTAINS INFORMATION CONFIDENTIAL AND PROPRIETARY TO SAMTEC, INC. AND SHALL NOT BE REPRODUCED OR TRANSFERRED TO OTHER DOCUMENTS OR DISCLOSED TO OTHERS OR USED FOR ANY PURPOSE OTHER THAN THAT WHICH IT WAS OBTAINED WITHOUT THE EXPRESSED WRITTEN CONSENT OF SAMTEC, INC.



520 PARK EAST BLVD, NEW ALBANY, IN 47150
 PHONE: 812-944-6733 FAX: 812-948-5047
 e-Mail: info@SAMTEC.com code: 55322

PLATING:
 CONTACT AREA: .000030 GOLD OVER .000050 NICKEL
 REMAINDER: .000200 REF TIN OVER .000050 NICKEL
 LATCHES: .000003 GOLD OVER .000050 NICKEL

DO NOT SCALE DRAWING SHEET SCALE: 3:1

DESCRIPTION: MODIFIED ERM8 ASSEMBLY

DWG. NO. ASP-137974-01

BY: David F 01/31/2008 SHEET 1 OF 2

ITEM NO.	PART NUMBER	QUANTITY	MATERIAL
1	ASP-136452-03-B	1.0000	VECTRA E130i, COLOR:BLACK
2	T-1M47-01-S	17.0000	PHOS BRONZE, 521 HT
3	T-1M47-03-S	17.0000	PHOS BRONZE, 521 HT
4	WT-29-07-F	2.0000	BeCu #25, 1/2 HT
5	TY-ASP122	1.0000	BLACK HIPS

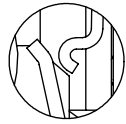

DETAIL 'G'
SCALE 6:1

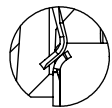

DETAIL 'H'
SCALE 6:1

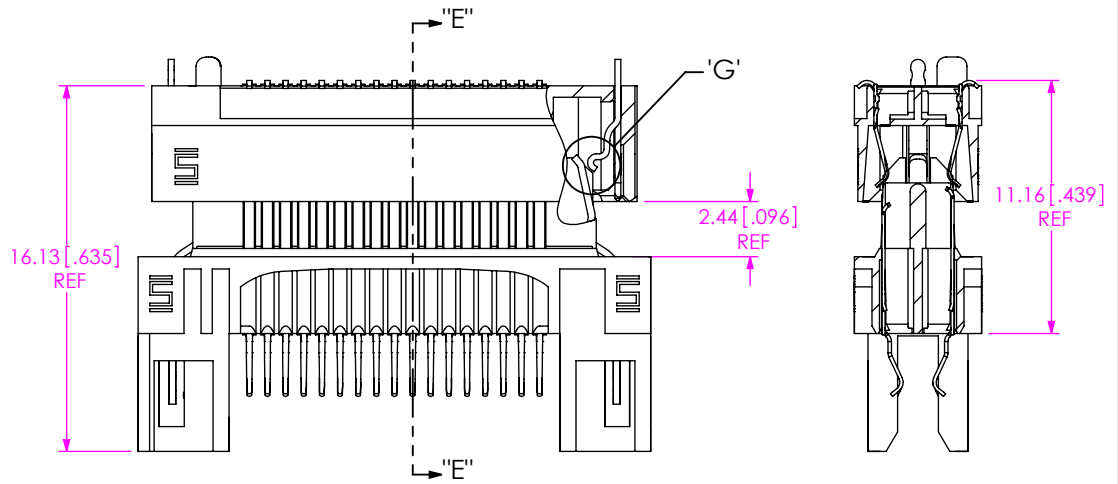

LATCH ENGAGING VIEW

SECTION "E"-"E"

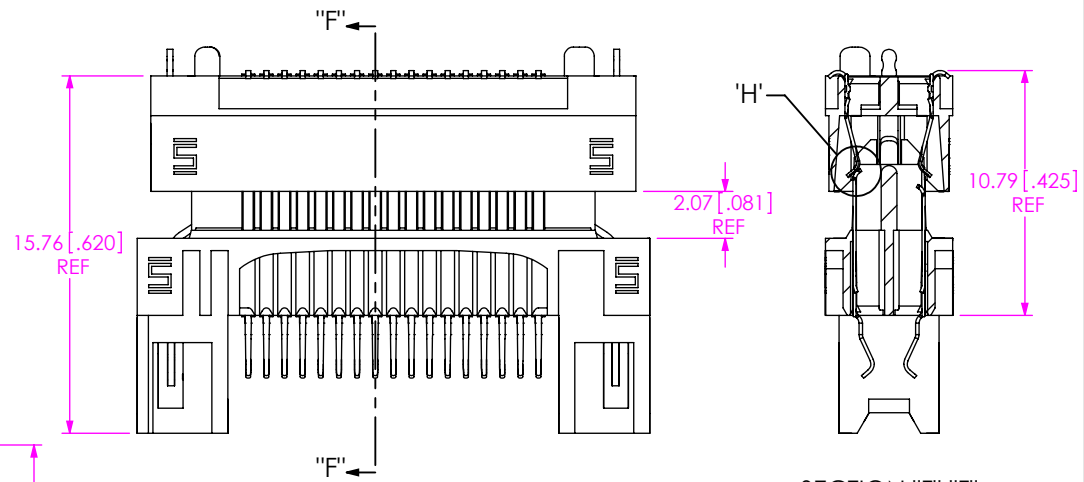

PIN ENGAGING VIEW

SECTION "F"-"F"

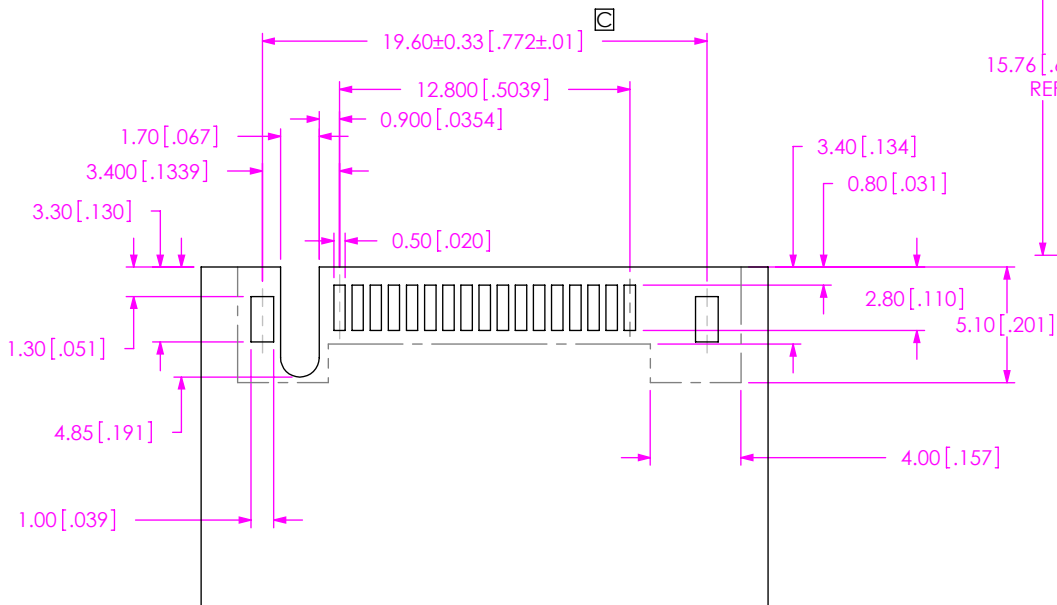

RECOMMENDED PCB LAYOUT

PROPRIETARY NOTE

THIS DOCUMENT CONTAINS INFORMATION CONFIDENTIAL AND PROPRIETARY TO SAMTEC, INC. AND SHALL NOT BE REPRODUCED OR TRANSFERRED TO OTHER DOCUMENTS OR DISCLOSED TO OTHERS OR USED FOR ANY PURPOSE OTHER THAN THAT WHICH IT WAS OBTAINED WITHOUT THE EXPRESSED WRITTEN CONSENT OF SAMTEC, INC.



520 PARK EAST BLVD, NEW ALBANY, IN 47150
PHONE: 812-944-6733 FAX: 812-948-5047
e-Mail: info@SAMTEC.com code: 55322

SHEET SCALE: 3:1

DESCRIPTION: MODIFIED ERM8 ASSEMBLY

DWG. NO. ASP-137974-01

BY: David F 01/31/2008 SHEET 2 OF 2