

DESIGNED & DIMENSIONED
IN MILLIMETERS [INCHES]

BNC7T-P-C-XX-ST-CA6

GENDER
-P: PLUG

TYPE
-C: CABLE

TERMINATION
-CA6: RG-6 CABLE

ORIENTATION
-ST: STRAIGHT

PLATING SPECIFICATION
-MN: MEDIUM GOLD/NICKEL (SEE NOTES 7 & 8)
(SUB-BNC7T-P-C-N-ST-CA6)
(BNC7-P-C-M-ST-CA6-PIN)
(BNC-FER-001-N)

DO NOT
SCALE FROM
THIS PRINT

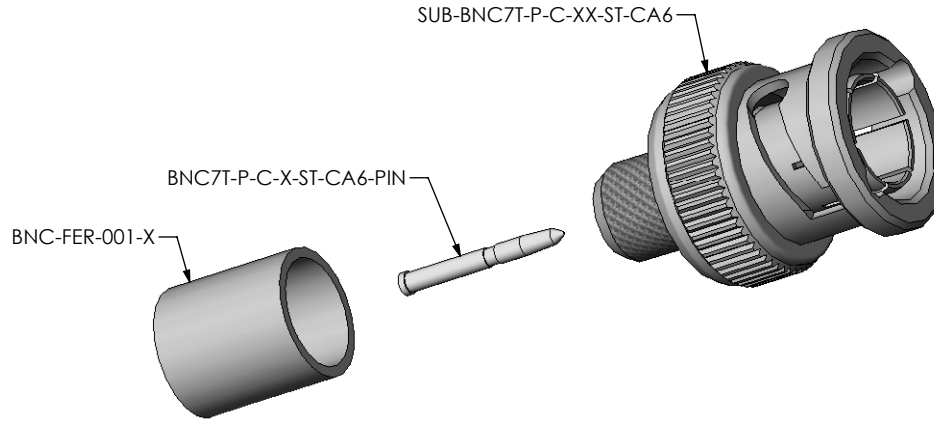
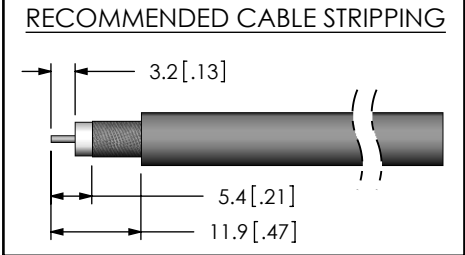

FIG.1
BNC7T-P-C-XX-ST-CA6 SHOWN

NOTES:

1. $\text{\textcircled{C}}$ REPRESENTS A CRITICAL DIMENSION.
2. PUSHOUT FORCE FOR CENTER CONTACT: 26.69 N [6.0 LB] MIN.
3. SEE SHEET 3 FOR TERMINATION INFORMATION.
4. NOTE DELETED.
5. PRODUCT TO BE PACKAGED PER PACKAGING STANDARD CO-HD-WI-3040-M.
6. RoHS COMPLIANT.
7. COMPONENT PLATING DESIGNATIONS:
-M: .000010" MIN. GOLD OVER .000050" MIN. NICKEL.
-N: .000100" MIN. NICKEL.
8. ASSEMBLY PLATING DESIGNATIONS:
-MN: (CENTER CONTACT)-M:
(OUTER CONTACT)-N:
(REMAINING METAL PARTS)-N:



**THIS PRODUCT MANUFACTURED
WITH LEAD-FREE PROCESSING**

F:\DWG\MISC\MKTG\BNC7T-P-C-XX-ST-CA6-MKT.SLDDRW

UNLESS OTHERWISE SPECIFIED DIMENSIONS ARE IN MILLIMETERS [INCHES] TOLERANCES ARE: DECIMALS ANGLES .X: ± 0.3 [.01] 2° .XX: ± 0.13 [.005] .XXX: ± 0.051 [.0020]	PROPRIETARY NOTE THIS DOCUMENT CONTAINS INFORMATION CONFIDENTIAL AND PROPRIETARY TO SAMTEC, INC. AND SHALL NOT BE REPRODUCED OR TRANSFERRED TO OTHER DOCUMENTS OR DISCLOSED TO OTHERS OR USED FOR ANY PURPOSE OTHER THAN THAT WHICH IT WAS OBTAINED WITHOUT THE EXPRESSED WRITTEN CONSENT OF SAMTEC, INC.
MATERIAL: SHELL, FERRULE, NUT: BRASS CONTACT: BRASS DIELECTRIC: PTFE GASKET: SILICONE	DO NOT SCALE DRAWING SHEET SCALE: 1:1



520 PARK EAST BLVD, NEW ALBANY, IN 47150
PHONE: 812-944-6733 FAX: 812-948-5047
e-Mail: info@SAMTEC.com code: 55322

DESCRIPTION: TRUE 75 OHM BNC STRAIGHT PLUG RG-6 $\text{\textcircled{D}}$
DWG. NO. BNC7T-P-C-XX-ST-CA6
BY: G. HERMAN 09/29/2008 SHEET 1 OF 3

REVISION D

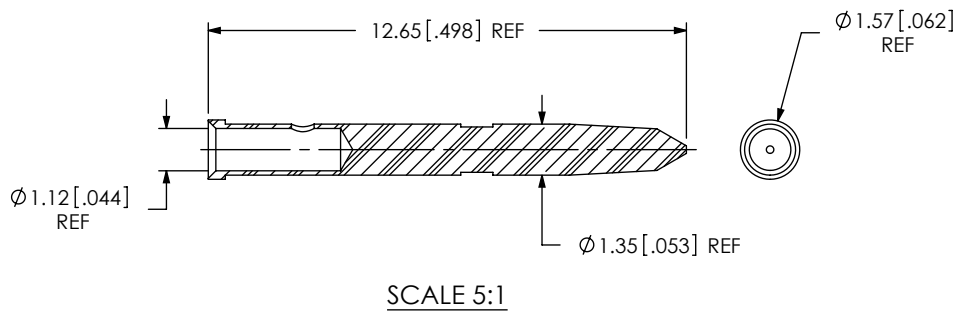

SAMTEC PART NUMBER	ITEM
BNC7T-P-C-X-ST-CA6-PIN	PIN

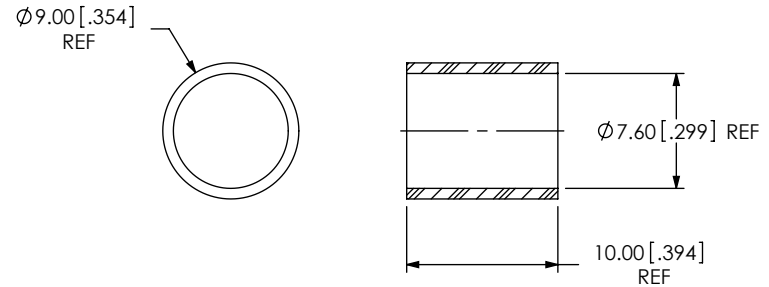

SAMTEC PART NUMBER	ITEM
BNC-FER-001-X	FERRULE

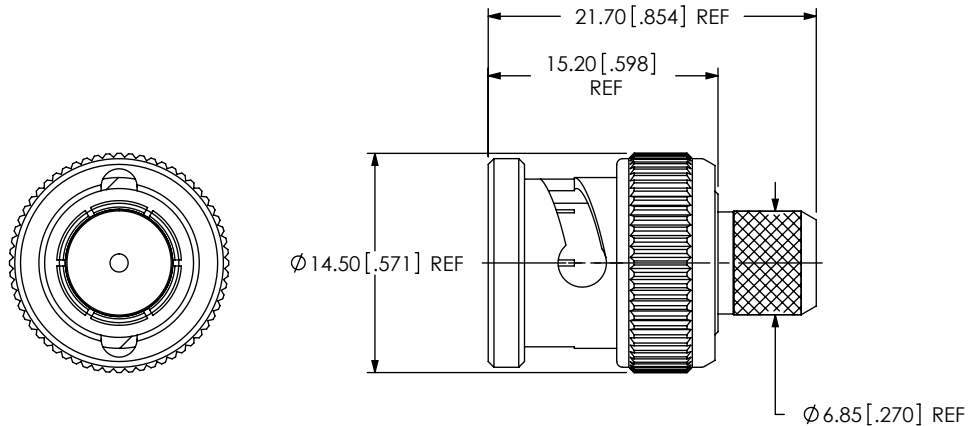

SAMTEC PART NUMBER	ITEM
SUB-BNC7T-P-C-XX-ST-CA6	SUB ASSEMBLY

F:\DWG\MISC\MKTG\BNC7T-P-C-XX-ST-CA6-MKT.SLDDRW

PROPRIETARY NOTE
 THIS DOCUMENT CONTAINS INFORMATION CONFIDENTIAL AND PROPRIETARY TO SAMTEC, INC. AND SHALL NOT BE REPRODUCED OR TRANSFERRED TO OTHER DOCUMENTS OR DISCLOSED TO OTHERS OR USED FOR ANY PURPOSE OTHER THAN THAT WHICH IT WAS OBTAINED WITHOUT THE EXPRESSED WRITTEN CONSENT OF SAMTEC, INC.

DO NOT SCALE DRAWING

SHEET SCALE: 2:1

samtec

520 PARK EAST BLVD, NEW ALBANY, IN 47150
 PHONE: 812-944-6733 FAX: 812-948-5047
 e-Mail: info@SAMTEC.com code: 55322

DESCRIPTION:
 TRUE 75 OHM BNC STRAIGHT PLUG RG-6

DWG. NO.
 BNC7T-P-C-XX-ST-CA6

BY: G. HERMAN 09/29/2008 SHEET 2 OF 3

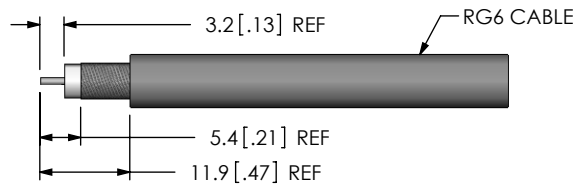

STRIP AND TIN INNER CONDUCTOR

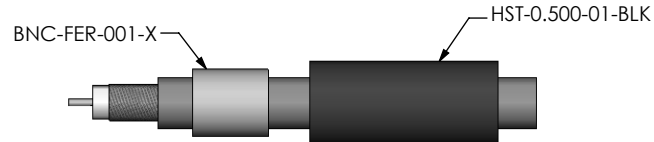

ADD HEAT SHRINK TUBE AND FERRULE

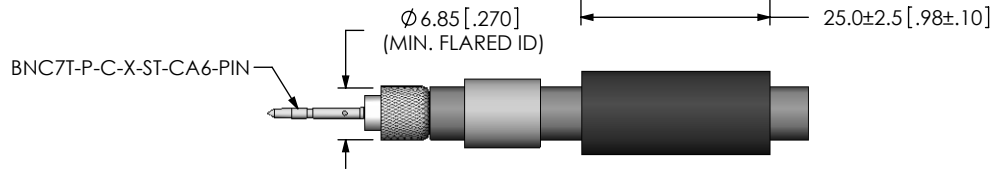

FLARE BRAIDED SHIELD AND ADD SIGNAL PIN

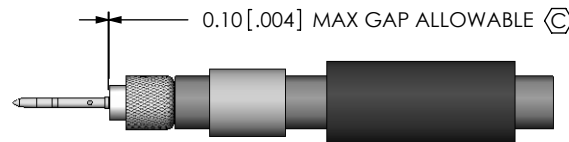

SOLDER SIGNAL PIN

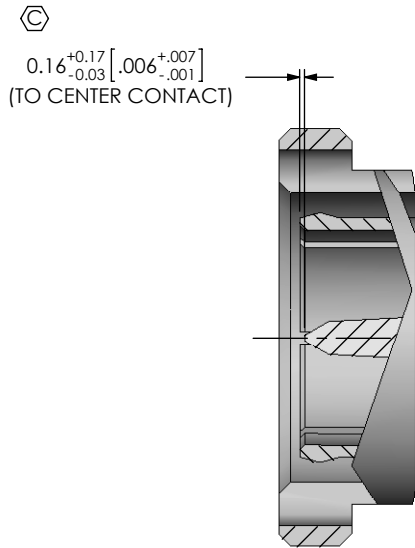

DETAIL 'A'
SCALE 4:1

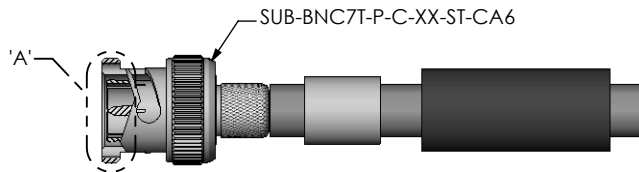

ADD SUB-BNC7T-P-C-XX-ST-CA6
CABLE FOIL WRAP TO BE INSERTED INSIDE CABLE BODY

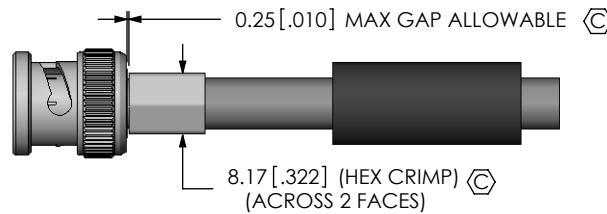

CRIMP FERRULE
(USE RF CRIMP HAND TOOL #CAT-HT-126667-21 OR EQUIVALENT)

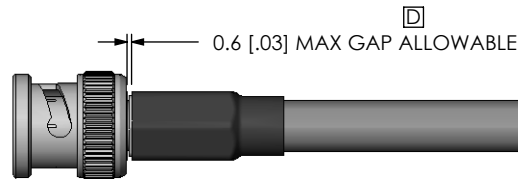

APPLY HEAT SHRINK TUBE

F:\DWG\MISC\MKTG\BNC7T-P-C-XX-ST-CA6-MKT.SLDDRW

PROPRIETARY NOTE

THIS DOCUMENT CONTAINS INFORMATION CONFIDENTIAL AND PROPRIETARY TO SAMTEC, INC. AND SHALL NOT BE REPRODUCED OR TRANSFERRED TO OTHER DOCUMENTS OR DISCLOSED TO OTHERS OR USED FOR ANY PURPOSE OTHER THAN THAT WHICH IT WAS OBTAINED WITHOUT THE EXPRESSED WRITTEN CONSENT OF SAMTEC, INC.

DO NOT SCALE DRAWING

SHEET SCALE: 1:1



520 PARK EAST BLVD, NEW ALBANY, IN 47150
PHONE: 812-944-6733 FAX: 812-948-5047
e-Mail: info@SAMTEC.com code: 55322

DESCRIPTION:
TRUE 75 OHM BNC STRAIGHT PLUG RG-6

DWG. NO.
BNC7T-P-C-XX-ST-CA6

BY: G. HERMAN 09/29/2008 SHEET 3 OF 3