

NOTES:

1. $\text{\textcircled{C}}$ REPRESENTS A CRITICAL DIMENSION.
2. SHEAR TAILS TO DIMENSION SHOWN.
3. MAXIMUM BURR: .003[0.08].
4. MAXIMUM CUT FLASH: .015 [0.38].
5. NO FLASH ALLOWED IN OR AROUND SURFACE MOUNT TAIL AREA.
6. MINIMUM PUSHOUT FORCE: .5 LB.
7. MINIMUM ENDWALL THICKNESS: .008 [0.20].
8. TUBES ARE STANDARD PACKAGING
9. ORDERS WILL BE PACKAGED ACCORDING TO THE SAMTEC PACKAGING EFFICIENCY STANDARDS (SPES) FOUND ON WWW.SAMTEC.COM
10. ATTACH LABEL TO EACH REEL

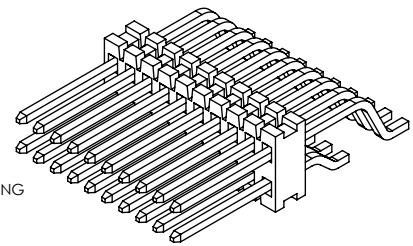

FTE-1XX-XX-X-DH-X-XX

No OF POSITIONS
-05 THRU -50
(PER ROW)

LEAD STYLE
-01: .075 POST
-02: .175 POST
-03: .120 POST

PACKAGING (SEE NOTES 9 & 10)

BLANK: TUBES (SEE NOTE 8)
-TR: TAPE & REEL PACKAGING (SEE FIG 3, SHEET 2)
-FR: FULL REEL QTY TAPE & REEL

PICK & PLACE OPTION
-K: POLYIMIDE FILM PAD (USE K-500-300, SEE FIG 4, SHEET 2)

ROW SPECIFICATION
-DH: DOUBLE HORIZONTAL (USE FTE-90-D)

PLATING SPECIFICATION
-G: 10 μ " SELECTIVE GOLD IN CONTACT AREA,
3 μ " SELECTIVE GOLD ON TAIL.

DO NOT SCALE FROM THIS PRINT

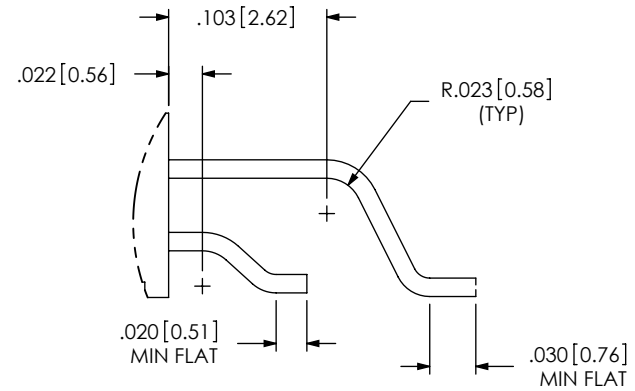
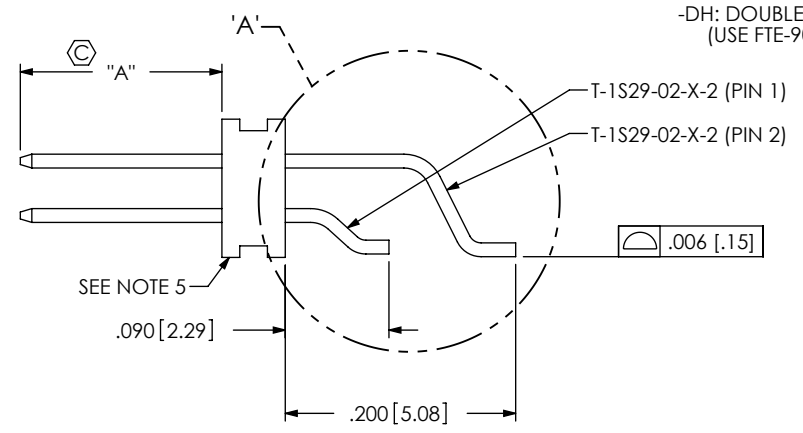
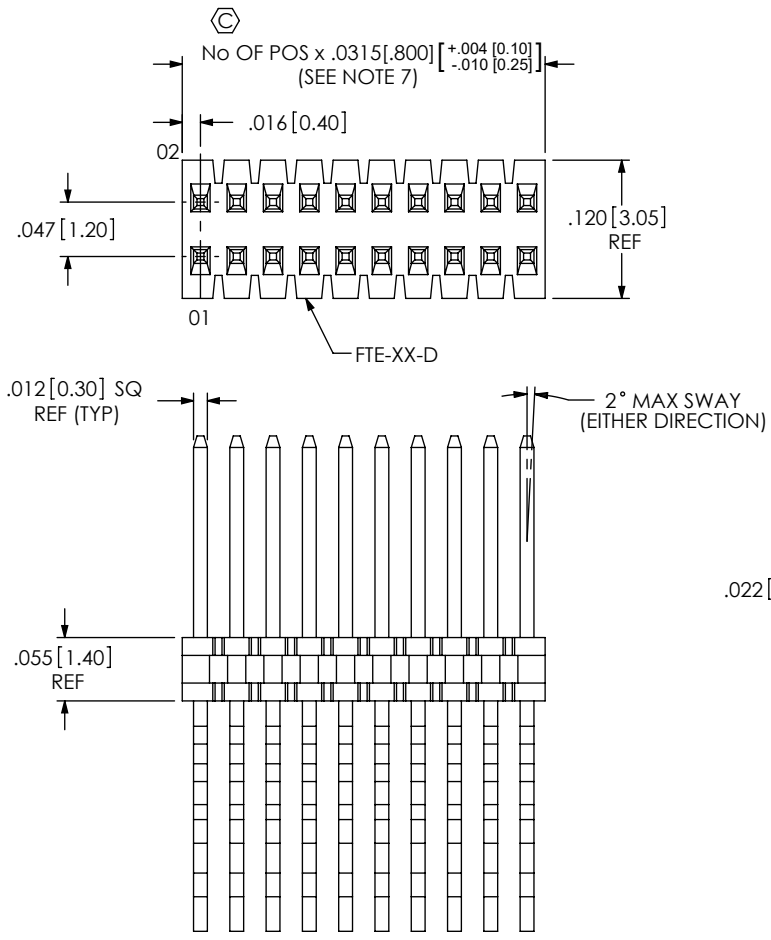

LEAD STYLE	"A"
-01	.075[1.91]
-02	.175[4.45]
-03	.120 [3.05]

FIG 1
FTE-110-02-X-DH SHOWN

DETAIL 'A'
SCALE 8:1

UNLESS OTHERWISE SPECIFIED, DIMENSIONS ARE IN INCHES. TOLERANCES ARE: DECIMALS ANGLES .XX: $\pm .01$ [0.3] 2° .XXX: $\pm .005$ [0.13] .XXXX: $\pm .0020$ [0.051]	PROPRIETARY NOTE THIS DOCUMENT CONTAINS CONFIDENTIAL AND PROPRIETARY INFORMATION AND ALL DESIGN, MANUFACTURING, REPRODUCTION, USE, PATENT RIGHTS AND SALES RIGHTS ARE EXPRESSLY RESERVED BY SAMTEC, INC. THIS DOCUMENT SHALL NOT BE DISCLOSED, IN WHOLE OR PART, TO ANY UNAUTHORIZED PERSON OR ENTITY NOR REPRODUCED, TRANSFERRED OR INCORPORATED IN ANY OTHER PROJECT IN ANY MANNER WITHOUT THE EXPRESS WRITTEN CONSENT OF SAMTEC, INC.		
		520 PARK EAST BLVD., NEW ALBANY, IN 47150 PHONE: 812-944-6733 FAX: 812-948-5047 e-Mail: info@SAMTEC.com code 53322	
MATERIAL: DO NOT SCALE DRAWING SHEET SCALE: 3:1	BODY: LCP, UL 94 V0, COLOR: BLACK TERMINAL: PHOS BRONZE	DESCRIPTION: .8MM X 1.2MM C.L. TERMINAL STRIP ASSM	DWG. NO. FTE-1XX-XX-X-DH-X-XX
BY: D. PURVIS 10/13/1998		SHEET 1 OF 2	

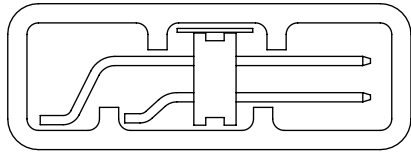

OPTIONS: -02, -03, -02-K, -03-K

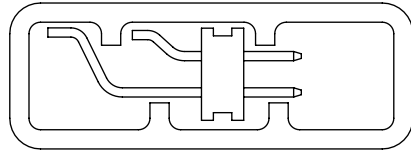

OPTIONS: -01, -01-K

FIG 2
TUBE: PT-FTE003-DH
PLUG: TP-12

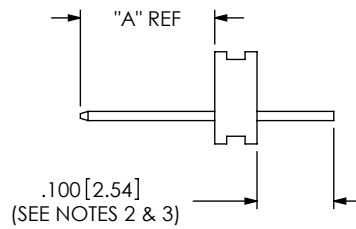

IN PROCESS 1

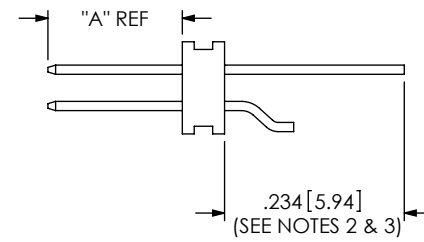

IN PROCESS 2

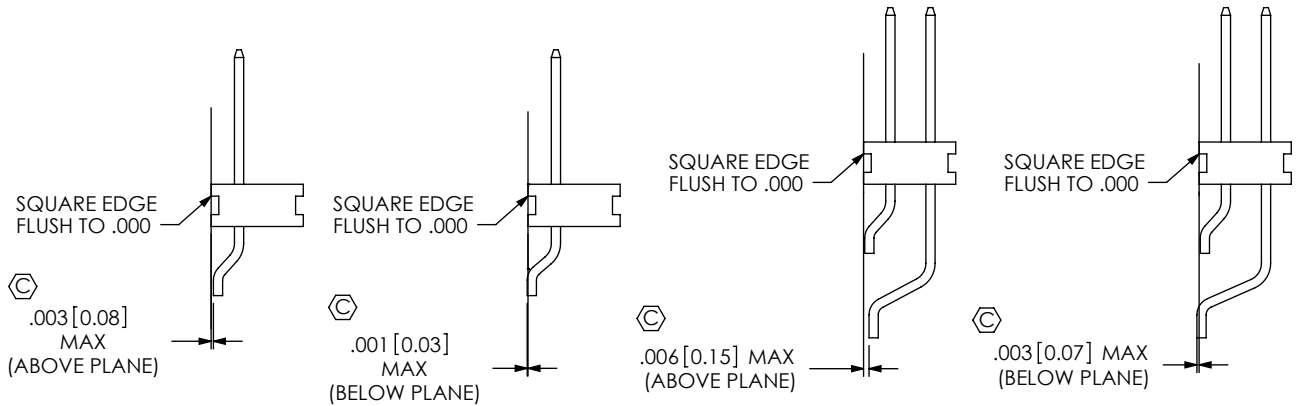

COPLANARITY VIEWS

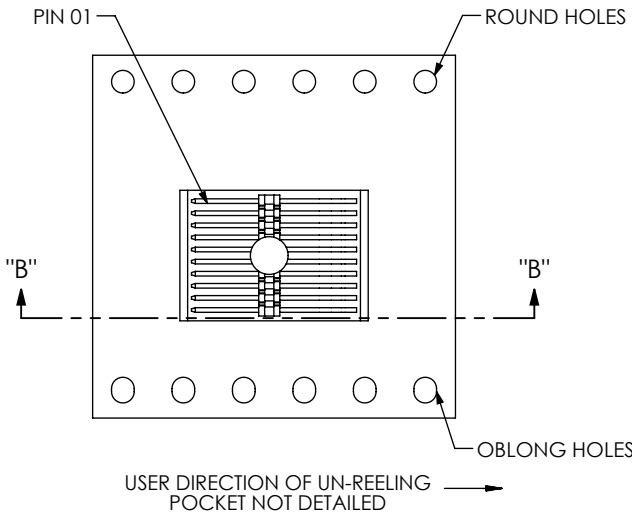

SECTION "B"- "B"
SCALE 2 : 1

FIG 3
TAPE & REEL

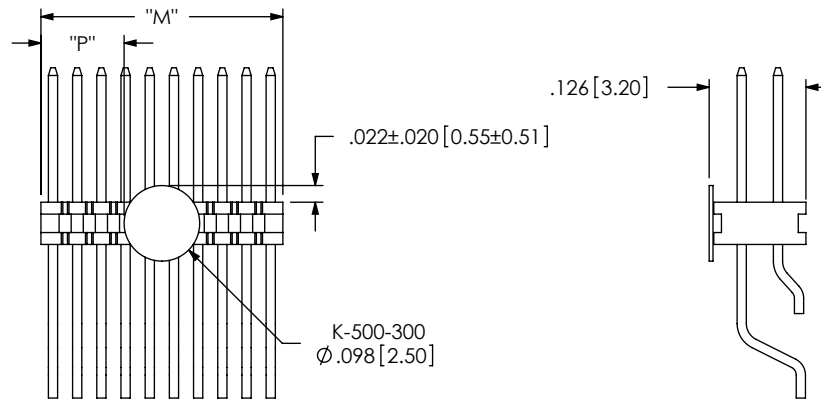

FIG 4
POLYIMIDE FILM PAD
(AVAILABLE ON -05 THRU -50 POS ONLY)

PROPRIETARY NOTE
THIS DOCUMENT CONTAINS CONFIDENTIAL AND PROPRIETARY INFORMATION AND ALL DESIGN, MANUFACTURING, REPRODUCTION, USE, PATENT RIGHTS AND SALES RIGHTS ARE EXPRESSLY RESERVED BY SAMTEC, INC. THIS DOCUMENT SHALL NOT BE DISCLOSED, IN WHOLE OR PART, TO ANY UNAUTHORIZED PERSON OR ENTITY NOR REPRODUCED, TRANSFERRED OR INCORPORATED IN ANY OTHER PROJECT IN ANY MANNER WITHOUT THE EXPRESS WRITTEN CONSENT OF SAMTEC, INC.

DO NOT SCALE DRAWING

SHEET SCALE: 4:1

NOTE: "M" = USE MEASURED DIMENSION REF
"P" = (("M" - .098[2.50]) / 2) ±.020[0.51]



520 PARK EAST BLVD, NEW ALBANY, IN 47150
PHONE: 812-944-6733 FAX: 812-948-5047
e-Mail info@SAMTEC.com code 55322

DESCRIPTION: .8MM X 1.2MM C.L. TERMINAL STRIP ASSM

DWG. NO. **FTE-1XX-XX-X-DH-X-XX**

BY: D. PURVIS 10/13/1998 SHEET 2 OF 2