

REVISION CF

DO NOT SCALE FROM THIS PRINT

DIMENSIONS ARE IN INCHES		TOLERANCES ARE:		TITLE: HIGH TEMP 2MM SMT BOARD STACKING TERMINAL STRIP ASM	DWG NO: TW-XX-XX-XXX-X-XXX-SM-XXX-XX
ONE PLACE DECIMALS ± .1 [2.5mm]	THREE PLACE DECIMALS ± .005 [0.13mm]	ANGLES ± 2°			
TWO PLACE DECIMALS ± .01 [0.25mm]	FOUR PLACE DECIMALS ± .0020 [0.05mm]				SHEET 1 OF 3

TABLE 1

LEAD STYLE	TERMINAL	MAX "A" ("B" IS .000 [.00] MIN)	"C" OVERALL PIN LENGTH
-02	T-1S13-02-XXX-2	.309 [7.85]	.377 [9.6]
-03	T-1S13-03-XXX-2	.467 [11.86]	.535 [13.6]
-04	T-1S13-06-XXX-2	.487 [12.37]	.555 [14.1]
-06	T-1S13-10-XXX-2	.605 [15.37]	.673 [17.1]
-07	T-1S13-11-XXX-2	.683 [17.35]	.751 [19.1]
-09	T-1S13-13-XXX-2	.388 [9.86]	.456 [11.6]

NOTES:

- MAX. PIN ROTATION IN BODY: 2°
- PUSHOUT FORCE SHALL BE 1 lb MIN.
- Ⓢ REPRESENTS A CRITICAL DIMENSION
- ALL DIMENSIONS IN BRACKETS [] TO BE MILLIMETERS.
- HEIGHT VARIATION BETWEEN ANY TWO PINS SHALL BE .010 MAX
- TUBE POSITIONS -04 THROUGH -36 ONLY; LAYER PACKAGE -02 & -03. TUBE PLUG MUST BE ALLIGNED WITH INSULATOR. (SEE DETAIL ON PAGE 2)
- MOLDED OR STAKED ALIGNMENT PIN AT SAMTEC'S DISCRETION.
- SPACE OPTION FROM .170 TO .209 REQUIRES AN ADDITIONAL REPRESS.
- MUST USE CARBIDE BLADES.
- M OPTION AVAILABLE ON -D ROW ONLY. -M OPTION AVAILABLE ON POSITIONS 4-36 ONLY. -P OPTION AVAILABLE ON 4-36 POSITION ONLY.
- DUE TO THE HIGH AMOUNT OF INSERTION FORCE NEEDED, THE -LC OPTION IS NOT COMPATIBLE WITH AUTO PLACEMENT. SAMTEC RECOMMENDS MANUAL PLACEMENT FOR ALL ASSEMBLIES WITH THE -LC OPTION.

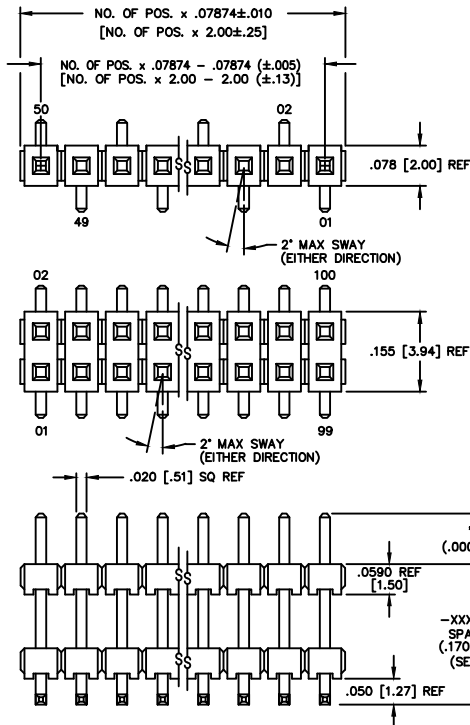

TW-XX-XX-XXX-X-XXX-SM-XXX-XX

No. OF POSITIONS EXPRESSED IN # OF POS (-02 THRU -36) "XX" = No OF POS x .07874 [2.00]

LEAD STYLE (SEE TABLE 1)

- PLATING
- G: 10μ" GOLD IN CONTACT AREA, 10 GOLD ON TAIL (USE T-1S13-XX-G-2)
 - T: MATTE TIN CONTACT AND TAIL (USE T-1SM3-XX-T-2)
 - S: 30μ" GOLD IN CONTACT AREA, MATTE TIN ON TAIL (USE T-1S13-XX-S-2)
 - E: 50μ" GOLD IN CONTACT AREA, 3μ" GOLD ON TAIL (USE T-1S13-XX-E-2)
 - L: 10μ" GOLD IN CONTACT AREA, MATTE TIN ON TAIL (USE T-1S13-XX-L-2)
 - F: 3μ" GOLD IN CONTACT AREA, MATTE TIN ON TAIL (USE T-1S13-XX-F-2)
 - P: 2μ" - 5μ" GOLD IN CONTACT AREA, MATTE TIN ON TAIL (USE T-1S13-XX-P-2)
 - TL: TIN/LEAD (90%/10 +/-5%) CONTACT AND TAIL (USE T-1S13-XX-TL-2)
 - STL: 30μ" GOLD IN CONTACT AREA, TIN/LEAD (90%/10 +/-5%) TAIL
 - LTL: 10μ" GOLD IN CONTACT AREA, (90%/10 +/-5%) TAIL (USE T-1S13-XX-LTL-2)
 - H: 30μ" GOLD IN CONTACT AREA, 3μ" GOLD ON TAIL (USE T-1S13-XX-H-2)
 - SM: 30μ" GOLD IN CONTACT AREA, MATTE TIN ON TAIL (USE T-1S13-XX-S-2)
 - TM: MATTE TIN CONTACT AND TAIL (USE T-1S13-XX-T-2)
 - LM: 10μ" GOLD IN CONTACT AREA, MATTE TIN ON TAIL (USE T-1S13-XX-L-2)
 - FM: 3μ" GOLD IN CONTACT AREA, MATTE TIN ON TAIL (USE T-1S13-XX-F-2)

- OPTION 1
- LC: LOCKING CLIP (SEE FIG 2, SHEET 2)(SEE NOTE 11) (-D ROW: USE 2TS-XX-D) (-S ROW: USE 2TS-XX-SV) (.190 MIN BOARD SPACE)
 - A: MOLDED ALIGNMENT PIN (SEE FIG 3, SHEET 2 & NOTE 7) (AVAILABLE IN 2-36 POSITIONS) (2 POSITIONS WILL ONLY HAVE ONE ALIGNMENT PIN) (-D ROW: USE 2TS-XX-DV-A) (-S ROW: USE 2TS-XX-SV-A) (BOTTOM BODY ONLY, USE TMM-50-X FOR TOP) STAKED ALIGNMENT PIN (SEE FIG 4, SHEET 2 & NOTE 7) (-D ROW ONLY: USE TMM-50-D, 4 POS MIN) (.190 MIN BOARD SPACE FOR BOTH)
 - P: PICK & PLACE PAD (SEE NOTE 10) (-D ROW: USE PPP-10) (-S ROW: USE PPP-11) NOTE: "B" = .075 [1.91] MIN FOR THIS OPTION (SEE FIG 6)
 - M: METAL PICK & PLACE PAD (SEE NOTE 10) (-D ROW: USE PPP-10) NOTE: "B" MUST BE .075 OR GREATER FOR THIS OPTION. (SEE FIG. 5)
 - TR: TAPE AND REEL PACKAGING (-07 LEAD STYLE NOT AVAILABLE IN T & R) (SEE SHEET 3 FOR -S-TR OPTION ORIENTATION VIEW) (.475 MAX "A" WHEN COMBINED WITH -P OPTION)
- OPTION 2
- XXX: POLARIZED POSITION (SPECIFY OMITTED PIN)
- SURFACE MOUNT
- SPACE OPTION (SEE NOTE B) XXX="A" (SEE TABLE 1, .170 [4.32] MIN)

- ROW OPTION
- S: SINGLE ROW (USE TMM-50-S)
 - D: DOUBLE ROW (USE TMM-50-D)

TABLE 2 (SEE NOTE 6)

LEAD STYLE	OPTIONS	TUBE	PLUGS
-02, -04, -07, -09	-D, -D-LC, -D-A	PT-TW001-D-SM	TP-03
-03	-D, -D-LC, -D-A	PT-TW001-D-SM	TP-03
ALL	-S, -S-LC, -S-A	PT-TW002-S-SM	TP-24-02
-02, -09	-D-A-P, -D-LC-P, -D-P, -D-LC-M, -D-A-M, -D-M	PT-TW001-D-SM	TP-03
-03, -04	-D-A-P, -D-LC-P, -D-P, -D-LC-M, -D-A-M, -D-M	PT-TW001-D-SM	TP-03
-07	-D-A-P, -D-LC-P, -D-P, -D-LC-M, -D-A-M, -D-M	PT-TW001-D-SM	TP-03
-02, -09	-S-LC-P, -S-A-P	PT-TW002-S-SM	TP-24-02
-03, -04	-S-LC-P, -S-A-P, -S-P	PT-TW002-S-SM	TP-24-02
-07	-S-LC-P, -S-A-P, -S-P	PT-TW002-S-SM	TP-24-02
-06	-D-LC	PT-TW001-D-SM	TP-03
-06	NONE, -A, -D	PT-TW001-D-SM	TP-03
-06	-D-A-P, -D-LC-P, -D-P, -D-LC-M, -D-A-M, -D-M	PT-TW001-D-SM	TP-03
-06	-S-LC-P, -S-A-P, -S-P	PT-TW002-S-SM	TP-24-02

PATENT NUMBERS
5713755 / 5961339

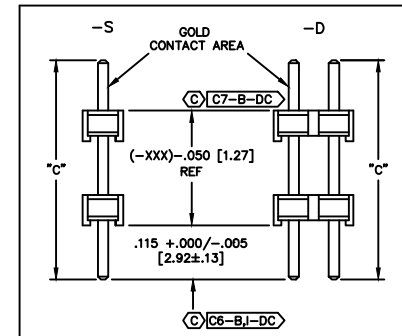

IN-PROCESS

PROPRIETARY NOTE
THIS DOCUMENT CONTAINS INFORMATION CONFIDENTIAL AND PROPRIETARY TO SAMTEC INC AND SHALL NOT BE REPRODUCED OR TRANSMITTED IN ANY FORM OR BY ANY MEANS, ELECTRONIC OR MECHANICAL, INCLUDING PHOTOCOPYING, RECORDING, OR BY ANY INFORMATION STORAGE AND RETRIEVAL SYSTEM, WITHOUT THE EXPRESS WRITTEN CONSENT OF SAMTEC INC.

MATERIAL:
INSULATOR: LIQUID CRYSTAL POLYMER
COLOR: BLACK
TERMINALS: PHOSPHOR BRONZE

EXSPROD/ASSEMBLY 2MM TW-SM

samtec

520 PARK EAST BLDV. NEW ALBANY, INDIANA 47150
PHONE (812) 944-8733 P.O. BOX 1147
CODE 55322

MADE BY: BRYANT 3-8-93

TW-XX-XX-XXX-X-XXX-SM-XXX-XX

