

SBS-120-01-S-DV-A-ML

SBS-120-01-S-DV-A-ML

0,80mm BLADE SOCKET SBS SERIES

SPECIFICATIONS

For complete specifications and recommended PCB layouts see www.samtec.com?SBS

Insulator Material:

Black Liquid
Crystal Polymer

Contact:

BeCu

Plating:

Au over 50µ" (1,27µm)

Ni on contact

Current Rating:

3.1A @ 30°C Temperature Rise

Operating Temp:

-55°C to +125°C

RoHS Compliant:

Yes

Processing:

Max Processing Temp:

230°C for 60 seconds, or

260°C for 20 seconds 3x

Lead-Free Solderable:

Yes

SMT Lead Coplanarity:

(0,10mm) .004" max

Mates with:
SiliconSystems
SiliconBlade
products



APPLICATION

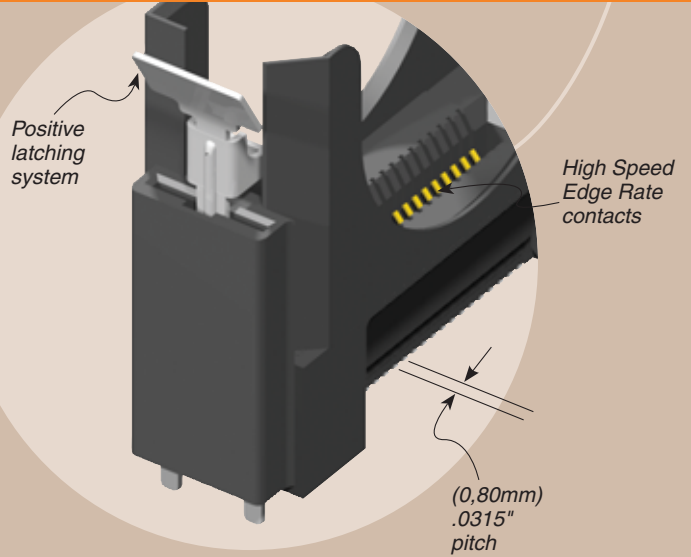

SBS	1	NO. OF PINS PER ROW	CARD THICKNESS	PLATING OPTION	DV	A	OTHER OPTION
		20	-01 = (1,60mm) .062" thick card	-S = 30µ" (0,76µm) Gold on contact, Matte Tin on tail			-ML = Metal Latch

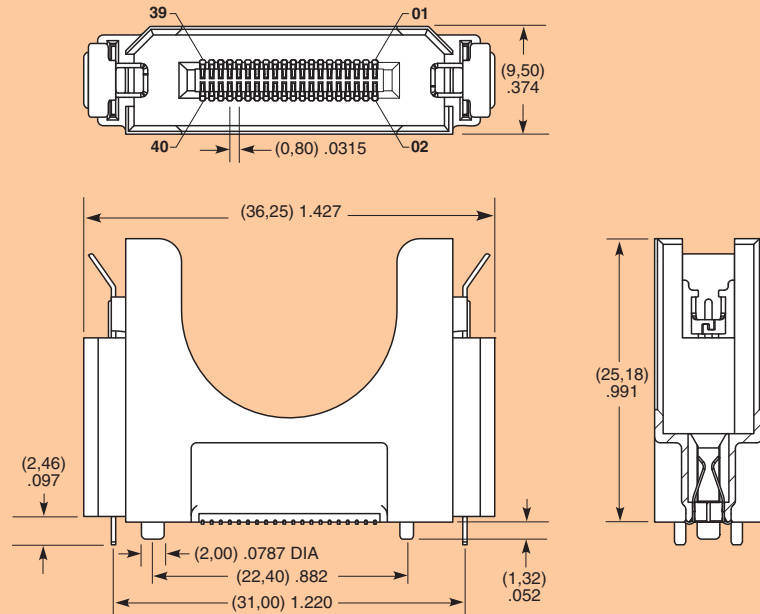

Note: Some lengths, styles and options are non-standard, non-returnable.

Due to technical progress, all designs, specifications and components are subject to change without notice.

WWW.SAMTEC.COM